

PQ Shaped Soft Ferrite Cores

MMG

Features

- Shape is optimized for core volume to winding area
- Maximum power output with minimum size
- Low assembly cost

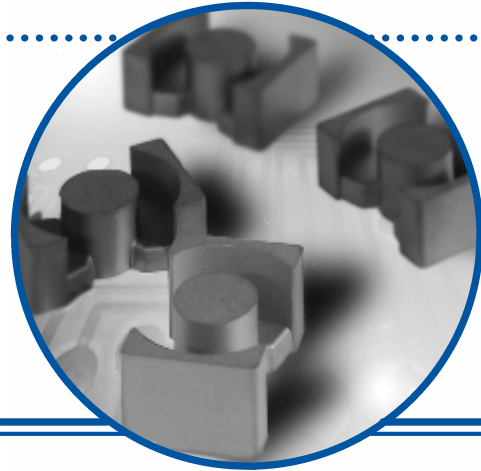

MMG is pleased to introduce our new line of PQ cores for use in aerospace, computer, medical, industrial, telecommunications and commercial power applications. Standard PQ cores are available in our low loss power grade ferrite materials. They are also available gapped to handle large dc bias currents upon request.

Mechanical Data

Dimensions [mm]	Core Type	
	PQ 20/16	PQ 20/20
A	20.50 ± 0.40	20.50 ± 0.40
B	8.10 ± 0.10	10.10 ± 0.10
C	14.00 ± 0.40	14.00 ± 0.40
D	5.15 ± 0.15	7.15 ± 0.15
E	18.00 ± 0.40	18.00 ± 0.40
F	8.70 ± 0.30	8.70 ± 0.30
G	12.00 min	12.00 min

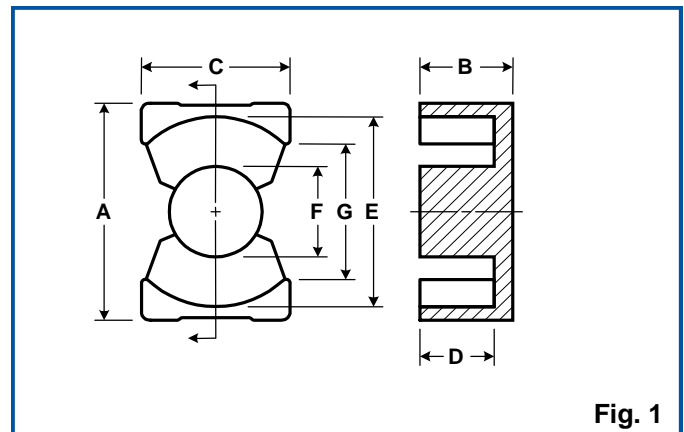

Fig. 1

Electrical Data

Core Type	Material	Effective Core Parameters					Part Number
		A_L [nH]	C_1 [mm ⁻¹]	L_e [mm]	A_e [mm ²]	V_e [mm ³]	
PQ 20/16	F44	3250 ± 25%	0.607	37.6	61.9	2330	29-040-44
PQ 20/16	F48	3880 ± 25%	0.607	37.6	61.9	2330	29-040-48
PQ 20/20	F44	2800 ± 25%	0.740	45.4	62.0	2790	29-050-44
PQ 20/20	F48	3300 ± 25%	0.740	45.4	62.0	2790	29-050-48

General Note

MMG reserves the right to make changes in product specification without notice or liability. All information is subject to MMG's own data and is considered accurate at time of going to print.

