

Hard Ferrite Arc Segment Tooling

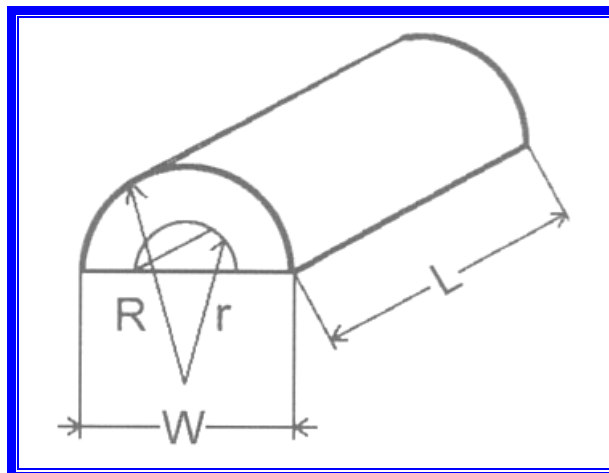

All the listed size tooling is readily available, but there may be some size variation as pressing characteristics may vary depending on material grade.

No	R	r	H	W	L	Remarks
1	16.8	12.0	-	30.0	37.0	150°
2	16.9	12.0	-	30.0	27.0	
3	17.5	12.2	12.4	31.4	31.2	
4	18.5	13.0	9.94	25.0	53.0	
5	19	14.6	12.7	33.5	40.0	
6	22	16.2	-	40.0	37.5	
7	21.5	16.8	15.5	39.2	38.1	
8	24.4	20.25	15.88	44.07	45.0	
9	26.92	20.57	49.28	63.5	17.5	
10	27.5	19.7	19.5	50.0	40.7	
11	27.5	19.7	19.5	50.0	41.0	
12	28.0	21.0	10.5	30.5	45.0	
13	28.0	21.5	19.4	50.0	50.0	
14	28.25	21.25	19.4	48.9	50.0	
15	28.5	25.5	19.5	50.5	36.0	
16	29.85	22.35	22.3	54.5	48.26	
17	29.85	22.35	22.3	54.5	27.94	
18	29.1	21.5	21.2	50.5	36.2	
19	29.1	21.5	21.2	51.6	45.0	
20	29.3	21.3	21.8	51.5	40.0	
21	30.18	23.5	22.0	56.79	69.98	
22	31.0	23.75	10.6	33.0	45.5.0	
23	31.0	25.7	-	33.0	41.0	
24	32.0	22.0	19.0	56.0	40.0	
25	32.0	29.5.0	22.1	59.5	37.5	

Hard Ferrite Arc Segment Tooling

No	R	r	H	W	L	Remarks
26	33.0	25.5	21.0	57.0	40.0	
27	34.0	25.6	22.0	60.0	60.0	
28	34.4	27.0	25.5	64.0	50.0	
29	34.44	26.98	26.1	60.0	66.0	
30	34.8	26.92	23.22	64.77	77.7	
31	35.0	26.5	24.5	61.0	40.0	
32	35.19	28.2	-	62.86	26.0	
33	35.37	28.19	-	54.4	17.0	
34	35.6	28.0	25.5	64.0	50.0	
35	35.6	28.75	24.5	64.0	41.0	
36	35.7	27.0	13.29	40.0	50.0	
37	35.7	27.0	24.6	64.0	100.0	
38	35.7	27.0	24.6	64.0	75.0	
39	36.17	27.05	26.42	65.43	88.9	
40	39.16	26.91	-	74.81	64.26	
41	40.5	30.55	21.0	71.0	32.0	
42	40.5	30.5	31.5	77.0	61.0	
43	42.88	24.26	24.26	56.8	82.55	
44	46.25	35.5	17.14	51.0	62.0	
45	47.5	38.5	33.0	85.0	72.0	
46	48.0	41.75	12.5	50.0	20.0	
47	49.5	40.6	14.3	52.0	25.0	
48	50.0	43.0	18.6	56.0	29.0	
49	50.6	38.8	-	87.0	61.5	
50	50.86	38.86	22.39	52.9	19.8	
51	51.65	39.0	41.7	99.0	115.0	
52	52.3	42.9	-	39.0	21.0	
53	52.3	42.9	-	75.0	24.5	
54	53.06	36.27	38.81	95.0	81.81	
55	54.95	47.25	20.3	75.0	24.5	
56	56.19	42.39	42.95	106.0	38.1	
57	62.27	53.79	-	54.59	23.5	52°
58	67.5	47.5	62.0	130.0	25.5	
59	78.23	67.95	-	70.33	28.58	
60	88°	143°	9.35	26.0	33.85	

